

# Media Asset Management: Archiving Considerations

Helen Hockx-Yu,  
Program Manager, Digital Asset Strategy

October 2018



INFORMATION TECHNOLOGIES

# University of Notre Dame



# University of Notre Dame

- Private research university with Catholic character
- Funded in 1842 by Edward F. Sorin, a priest of the Congregation of Holy Cross
- “a powerful force for good”
- Located adjacent to South Bend, Indiana
- Athletic teams known as the “Fighting Irish”



## ATHLETICS

Baseball  
Basketball  
Cross Country  
Fencing  
Football  
Golf  
Ice Hockey

Lacrosse  
Soccer  
Swimming and Diving  
Tennis  
Indoor Track and Field  
Outdoor Track and Field

## WOMEN'S

Basketball  
Cross Country  
Fencing  
Golf  
Lacrosse  
Rowing  
Soccer

Softball  
Swimming and Diving  
Tennis  
Indoor Track and Field  
Outdoor Track and Field  
Volleyball

> [und.com](http://und.com)

## ACHIEVEMENTS/MILESTONES

# TOP 25

Notre Dame is rated among the nation's top 25 institutions of higher learning in surveys conducted by *U.S. News & World Report*, *Forbes*, *Niche*, and others.

## NOTRE DAME LAW SCHOOL IS RATED 20TH BY *U.S. NEWS & WORLD REPORT*.

Notre Dame established the first programs in law, engineering, and architecture at an American Catholic institution of higher learning.



Twenty-four Notre Dame faculty members, including current President Rev. John I. Jenkins, C.S.C., have been elected to the American Academy of Arts and Sciences, the nation's leading learned academy.

## FACULTY AND PROGRAM STATISTICS



## A TOP 10 COLLEGIATE WORKPLACE

Notre Dame has been identified as one of the top 10 collegiate workplaces in the country in a survey by the *Chronicle of Higher Education*, the leading resource for higher education news and information.



## THE MENDOZA COLLEGE OF BUSINESS

is ranked **No. 2** nationally for its undergraduate program by *Bloomberg Businessweek* in its 2016 survey of top business programs. The program also is ranked **No. 2** by *Poets & Quants* in its inaugural 2016 survey of top undergraduate business schools.

Faculty in the College of Arts and Letters have earned **61 fellowships** from the National Endowment for the Humanities since 1999, more than for any other university in the nation over that time.

Notre Dame's Medieval Institute was the first in the United States, and the University also founded the first publication series dedicated specifically to medieval topics.

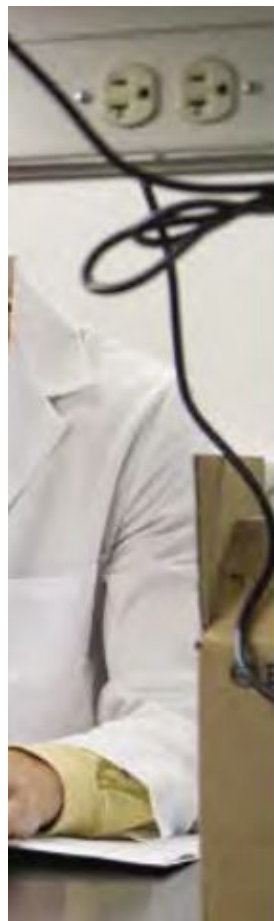

# #1

in the country  
for NEH  
Fellowships  
since 1999

# \$138

million in record-breaking  
research awards in FY17

## GLOBAL FOOTPRINT



## CURRENT AWARDS BY SPONSOR

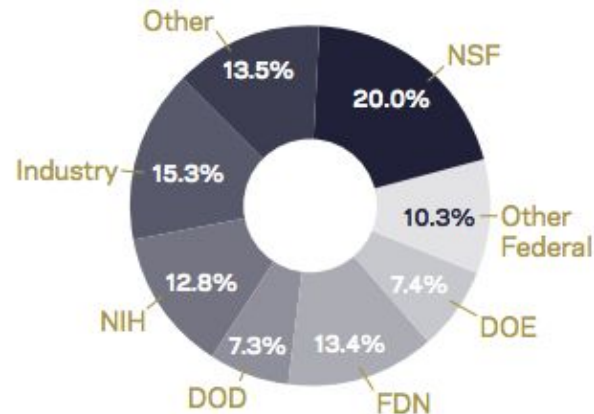

# Centralised Campus Media Production Facility



# Notre Dame Studios



- Provides technical and staff support for campus multimedia production
- Includes control rooms, studios and editing spaces
- Supports live and pre-produced video programming
- Home to video producers from many departments



## Digital Media @Notre Dame

- Frequent use of digital media for education, research, special events, faith-based services, athletic competitions & performances
- Video assets estimated to measure -2PB at present, and growing
- Assessment project in 2017 recommended CatDV as enterprise video asset management application
- Currently running new project to make CatDV enterprise-ready

# What is CatDV

- Media asset management application created by UK-based software company Square Box
- Organize, describe, locate and control media assets such as videos, still images, audio files and PDFs
- Common features include asset ingestion, logging and clipping, metadata management, browse and search, and transcoding
- Integrated with non-linear editing software such as Final Cut Pro and Adobe Premiere
- Operates with tiered storage solutions, keeping track of media assets and their locations
- Already used by departments on campus

# Expanding CatDV

- Infrastructure already in place including Spectra Logic T950 Tape Library and 600TB SAN
- Also some CatDV licence + middleware appliance & licence, meeting the needs of current users
- CatDV as enterprise solution requires integration with campus IT infrastructure, additional licence, backup & Disaster Recovery provision and storage
  - Also a business model to support and sustain campus use
  - Service documentation, training and support
- Specific academic use cases still needs to be addressed (e.g. psychology)

# Hosted Media Management Solution

- Balancing performance, security and redundancy
- Media management application: CatDV
- 3-tiers of storage (via orchestration of BlackPearl)
  - Fast SAN storage to support operational use
  - Secure, cost-effective tape storage to accommodate growth
  - Disaster recovery to avoid catastrophic data loss (Cloud storage)
- 4 copies of assets (2 x original, 1 x mezzanine, 1 x proxy)
  - Standard for content creators

- Desktop Client
- Web Clients
- CatDV Server
- CatDV Worker
- REST API

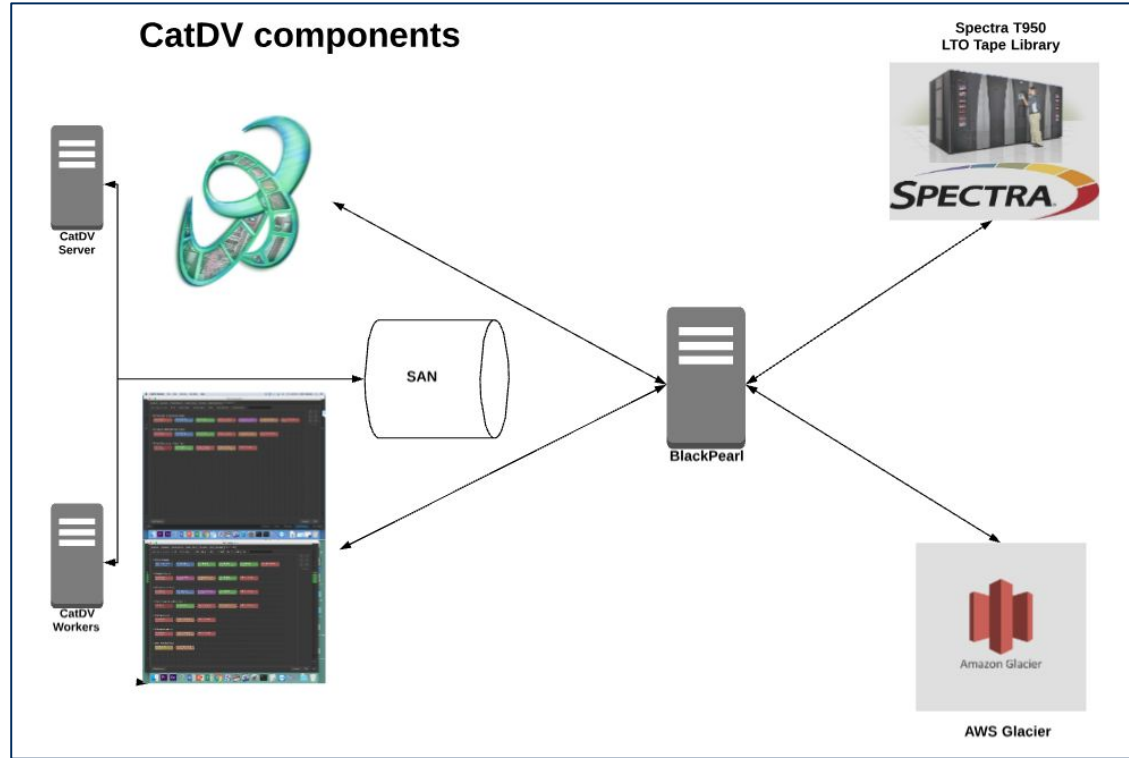

## Video Asset Management Data Model

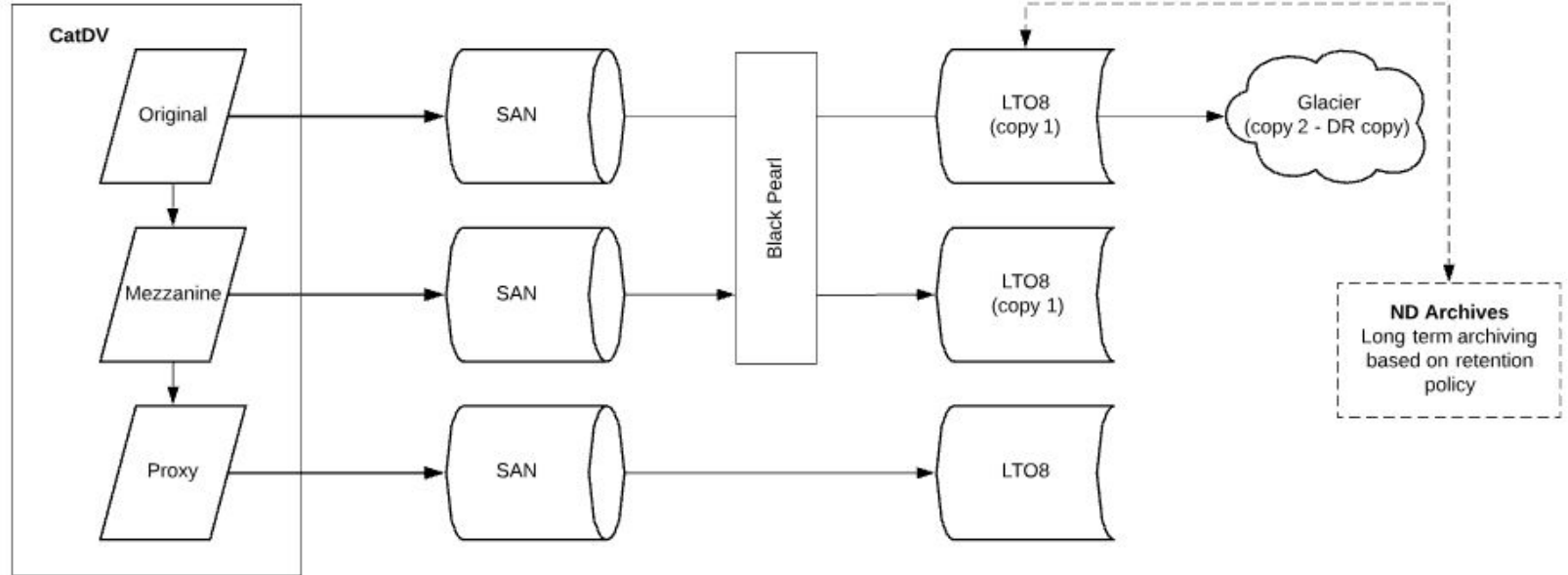

# Archiving and archiving

- archiving (to tape)
  - Moving less active files from spinning disk storage to tape storage
  - Tape Library, tape archive
- Society of American Archivists
  - Archives with capital A: permanent valuable records
  - archives: an organisation dedicated to preserving the documentary heritage of a particular group
- University Archives: collecting, maintaining and preserving official records of UND

# archiving to Tape

- Previously
  - Manual process moving/restoring files outside CatDV (using Archiware)
  - Need to restore and reingest data
- Now
  - BlackPearl integrated into CatDV
  - Users can directly archive and restore content to/from BlackPearl using CatDV desktop or web client - can schedule jobs



# Transcoding using FFmpeg

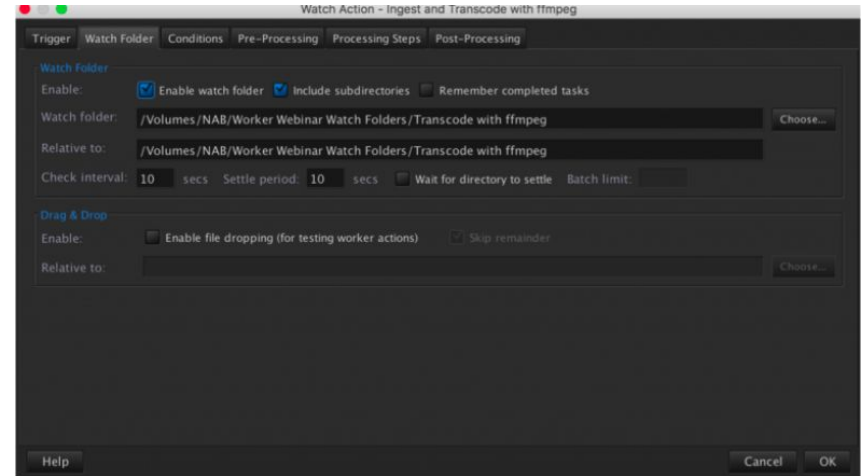
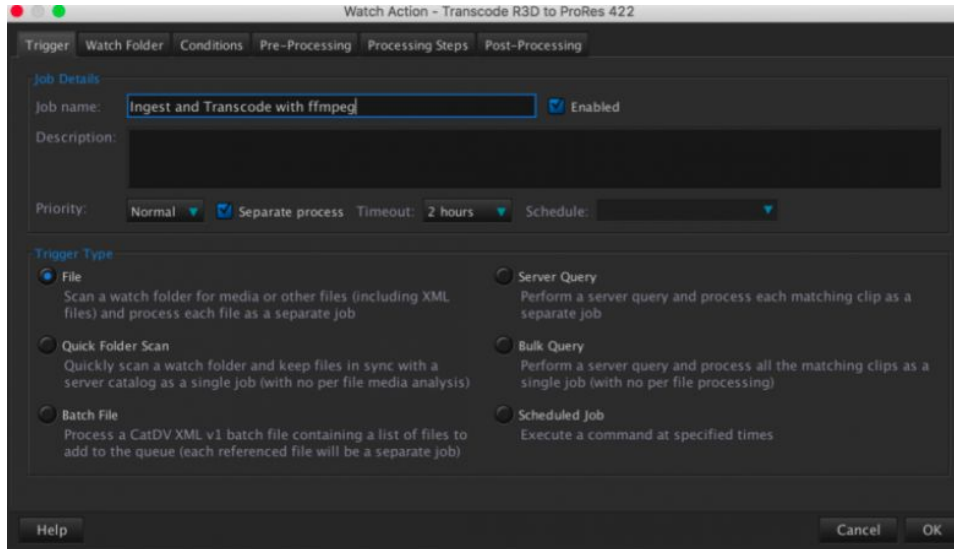

# University Archives

- 240TB digitised material
  - Analogue video & audio, photos, print publications
  - 70% of AV are sports-related; 6% MarCom
- 140TB born-digital material
  - Athletics, MarCom, Development
- 78,000 items on physical carriers (film, audio, video)
  - All catalogued, 20% - 25% digitised
- Stored in Tape Library (as mounted volumes) via Dternity
- Getting a digital preservation system



# Digital Preservation in DAMs

- DAMs in general not designed to support Archiving and preservation workflows
  - Checksum - main use case is file de-duplication
  - Metadata - no built-in templates for common metadata schema
  - File formats



# Challenges and way forward

- Still a large amount of content on physical carriers - digitisation based on risk & demand
- Separation of content (historical and operational)
  - Consolidation of discovery and storage?
- Dis-alignment between abundance of data and institutional capacity for long-term archiving and preservation
  - Finished products as historical records do not necessarily support access / re-use
- Retention schedule
- How can IT support records creators and University Archives?
- Collaboration
  - Can CatDV serve DIPs for Archives?
  - Can Archives provide guidelines re. records of enduring value